

RELEASE HISTORY		
a	DRAWING/DESIGN CREATED Rev.0	10.07.1991 DSS
b	DRAWING REDRAWN Rev.1	27.04.2021 RVS

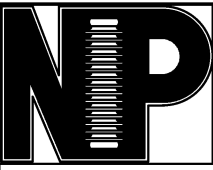

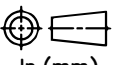

PART# 47805-7001
 In.(mm)
 DRAWING NUMBER 212-C-271

TITLE STATION POST INSULATOR-900KV BIL

REF. TECHNICAL REFERENCE TR-304

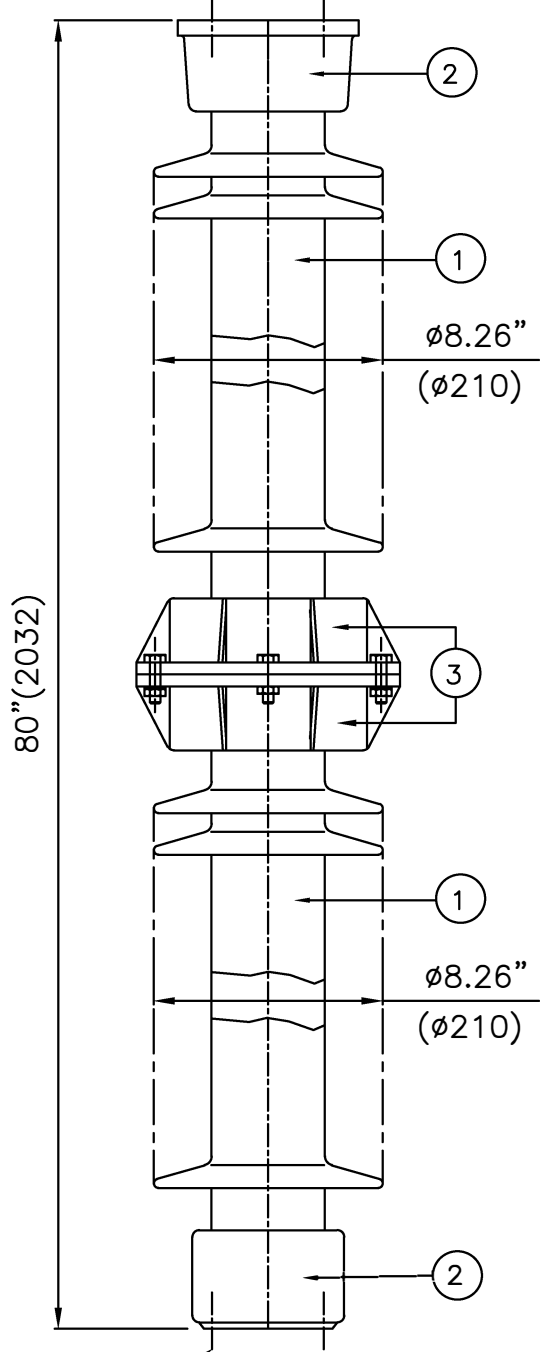
4 Holes 5/8"-11UNC (0.015" Oversize)
X 0.866 deep on 5" PCD



4 Holes 5/8"-11UNC (0.015" Oversize)
X 0.866" deep on 5" PCD

TECHNICAL CHARACTERISTICS

MECHANICAL RATINGS

CANTILEVER STRENGTH, lbs (kN) (Upright & Underhung)	950 (4.22)
TENSION STRENGTH, lbs (kN)	20000 (89)
TORSION STRENGTH in-lbs (kN*M)	40000 (4.52)
COMPRESSION STRENGTH lbs (kN)	60000 (267)

ELECTRICAL RATINGS

IMPULSE WITHSTAND VOLTAGE, kV	900
CRITICAL IMPULSE FLASHOVER VOLTAGE, POSITIVE, kV	1010
WET POWER FREQUENCY WITHSTAND VOLTAGE, kV	385

RADIO INFLUENCE VOLTAGE RATINGS

LOW FREQUENCY TEST VOLTAGE, kV	146
MAX. RIV AT 1000 kHz, μV	500

PHYSICAL CHARACTERISTICS

MINIMUM LEAKAGE DISTANCE, in (mm)	165 (4191)
UNIT HEIGHT, in (mm)	80 (2032)
NET WEIGHT, lbs (kg)	246 (112)
GLAZE COLOR	Light Gray
APPLICABLE STANDARD:ANSI:C29.9 & IEC:60168,273 & IS:2544, 5350	

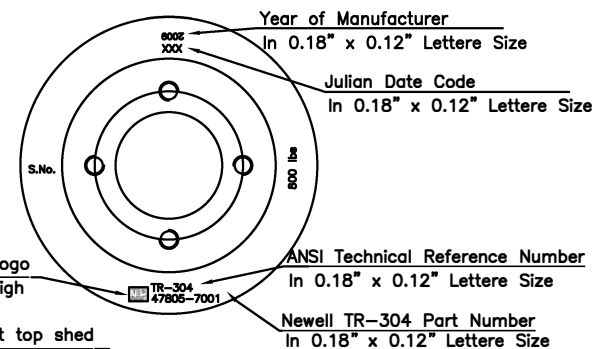

S.No.	DESCRIPTION	MATERIAL	REMARKS
2 & 3	Caps & Flange	MCI/SGI	Hot dip.galv.
1	Insulator body	Al.Porcelain	Grey Glazed

REF.212-C-271	DWG.TYPE SALES	DWN. RVS	APP.
---------------	----------------	----------	------